

## PC Board Holder



Novoflex PC Board Holder is designed to provide permanent locking for chassis. For modification or service, the PCB can be pulled out easily by just pinching the head with finger or simple plier. It can snap into 3.2 mm diameter hole of 1.6 mm thick chassis & PCB.

**Material:** Nylon 6 (Polyamide). Resistant to Fungus, Corrosion, and most mild acids.

**Flammability Rating:** UL94 V-2

**Standard Colour:** Natural White.

**Operating Temperature:** -25° C to +85° C.

**Storage Conditions:** To be stored in a cool, dark, dry place away from sunlight in a sealed condition.

**Example Applications:** Automobiles, Railways, Aviation, Power Plants, Telecom, Consumer Durables, Retail Stores, Electric Metering, Electronics, Control Panels and many more.

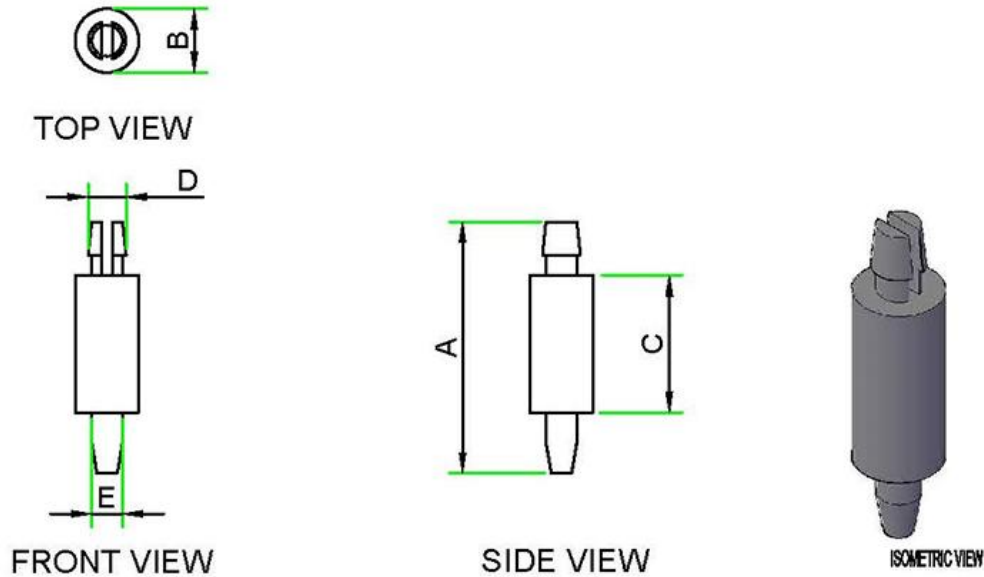

### NOVOFLEX - PC Board Holder

Novoflex Part No.	Length (A) - mm	Width (B) - mm	Spacing Length (C) - mm	Lock Head Dia (D) - mm	Lock Head Dia (E) - mm	Standard Packing (Nos.)
PCBH 113	24.4	6.2	13.3	3.8	2.9	100