

Screw Mount Tube PCB Support

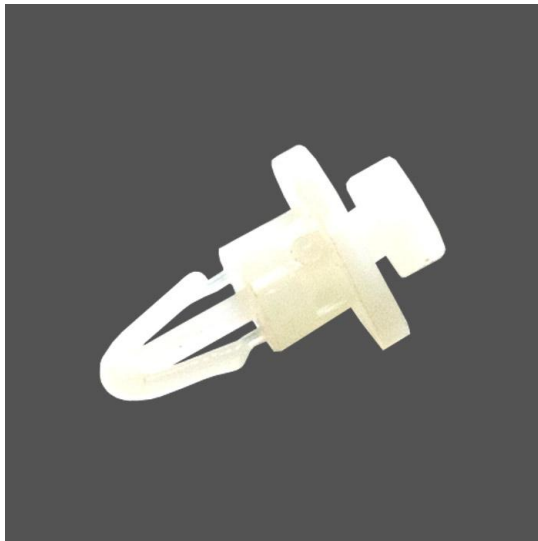

Novoflex Slide Secure Style PCB Supports is designed to allow for easy removal and facilitate repairs. The larger base on slide secure side provides easy identification of mounting end. The support is installed easily by hand and no tool, screw, bolt or nut is required for mounting.

Material: **Nylon 6 (Polyamide)**. Resistant to Fungus, Corrosion, and most mild acids.

Tolerance: ± 0.50 mm.

Flammability Rating: **UL94 V-2**

Standard Colour: Natural White.

Continuous Operating Temperature: -25° C to +85° C.

Intermittent Operating Temperature: +115° C.

Storage Conditions: To be stored in a cool, dark, dry place away from sunlight in a sealed condition.

Example Applications: Automobiles, Railways, Aviation, Power Plants, Telecom, Consumer Durables, Retail Stores, Electric Metering, Electronics, Control Panels and many more.

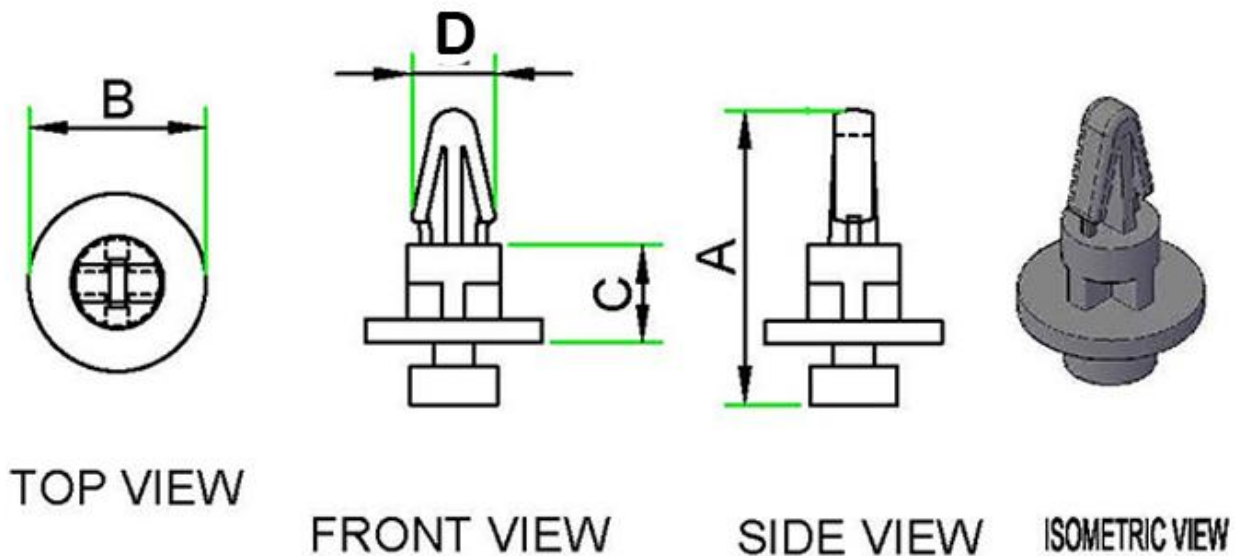

NOVOFLEX - Slide Secure Style PCB Supports

| Novoflex Part No. | Length (A) - mm | Width (B) - mm | Spacing Length (C) - mm | Push Hole Dia (D) - mm | Plate Thickness - mm | Standard Packing Nos. |
|-------------------|-----------------|----------------|-------------------------|------------------------|----------------------|-----------------------|
| PCBW 64 | 19.4 | 11.7 | 6.4 | 4 | 1.5 | 100 |

