

Anchorhead Disc Clip



Novoflex AnchorHead Disc Clips can be used to secure corrugated tubing along the length of the chassis, without the need of any fixing tool. This can be done by simply pushing the anchor head through the chassis/fixing point and routing the corrugated conduits through the adjustable clamping portion. The adjustable locking strap allows for corrugated conduits of various diameters to be securely fastened and provides a tight grip thereby preventing unwanted movement. The anchor fits securely into the hole of your chassis, providing a solid, rattle-free installation. When fully inserted, the disc at the bottom of the clip seals the hole completely and provides additional protection from outer elements such as dust, water, mild acids, and oils thereby increasing the life of the wiring system exponentially.

Material: UL Listed Nylon 6.6. Resistant to Fungus, Corrosion, and most mild acids. Can also be manufactured in HSB, HTR, FR materials or customer specific colours specific to MOQ.

Flammability Rating: UL94 V2.

Standard Colour: UV Resistant Black (B).

Operating Temperature: -25° C to +85° C.

Halogen Free: Yes.

Storage Conditions: To be stored in a cool, dark, dry place away from sunlight in a sealed condition.

Example Applications: Wiring Harness, Automotive, 2 Wheelers, Aviation, Commercial Vehicles, Control Panels and Heavy Equipment manufacturing industries.

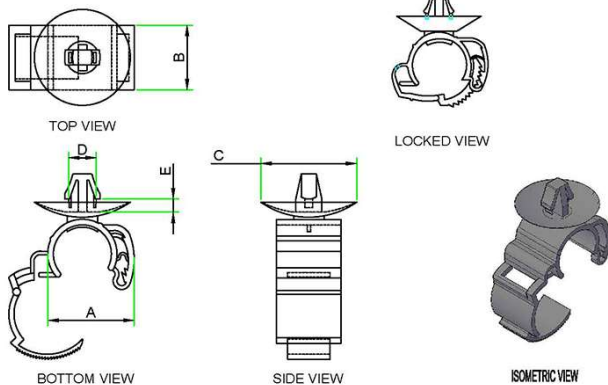

NOVOFLEX - Anchorhead Disc Clip

Novoflex Part No.	Length (A) - mm	Width (B) - mm	Dome Seal Dia (C) - mm	Push Hole Dia (D) - mm	Chassis Thickness (E) - mm	Suitable For Cable / Pieve Dia- mm	Standard Packing (Nos.)
ADC 1315	21	15	22	6.5 - 7.0	1.0 - 2.5	13.0 - 15.0	100